

salton®

Automatic Rice cooker



Instruction Booklet

Model: RC-1211

IMPORTANT SAFEGUARDS

When using electrical appliances, basic safety precautions should always be followed including the following:

1. Read all instructions.
2. Do not touch hot surfaces. Use handles or knobs.
3. To protect against electrical hazards, do not immerse cord, plugs, or the appliance in water or other liquid.
4. Close supervision is necessary when any appliance is used by or near children.
5. Unplug from outlet when not in use and before cleaning. Allow to cool before putting on or taking off parts.
6. Do not operate any appliance with a damaged cord or plug or after the appliance malfunctions, or has been damaged in any manner. Return appliance to Salton for examination, repair or adjustment. See Warranty.
7. The use of accessory attachments not recommended by Salton may cause hazards.
8. Do not use outdoors.
9. Do not let cord hang over edge of table or counter, or touch hot surfaces.
10. Do not place on or near a hot gas or electric burner, or in a heated oven.
11. Extreme caution must be used when moving an appliance containing hot liquids.
12. To disconnect, remove plug from wall outlet.
13. CAUTION: This appliance generates heat and escaping steam during use. Proper precautions must be taken to prevent the risk of burns, fires or other damage to persons or property.
14. This appliance generates steam. Do not operate uncovered.
15. Do not leave this appliance unattended during use.
16. This appliance is for household use only. Do not use appliance for other than intended use.
17. Do not place the Rice Bowl on other heat sources (e.g. cooking stove). It may become deformed.
18. Do not block the Steam Vent Hole.
19. During or immediately after cooking, the area near the Steam Vent Hole is kept at high temperature. To avoid burns do not touch this area.
20. To reduce the risk of electric shock, cook only in the removable container.

SAVE THESE INSTRUCTIONS

HOUSEHOLD USE ONLY

POLARIZED PLUG

This appliance has a polarized plug (one blade is wider than the other). To reduce the risk of electric shock, this plug will fit in a polarized outlet only one way. If the plug does not fit fully in the outlet, reverse the plug. If it still does not fit, contact a qualified electrician. Do not modify the plug in any way.

INTRODUCTION

The Salton Rice Cooker provides a simple, trouble free method for cooking perfect rice.

Please read this Instruction Booklet before using your Salton Rice Cooker and keep it in a safe place for future reference.

KNOW YOUR RICE COOKER

1. Glass Lid
2. Rice Bowl
3. Base
4. Keep Warm Indicator Light
5. Cooking Indicator Light
6. Switch
7. Heating Plate
8. Heat Sensor
9. Measuring Cup
10. Spatula

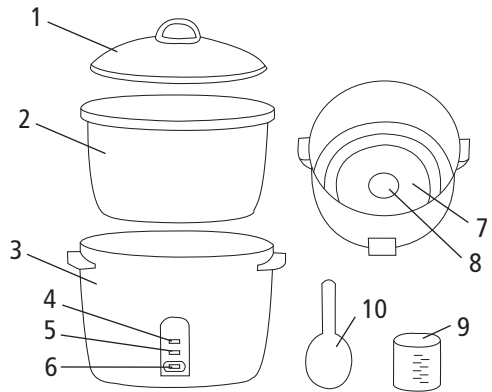

BEFORE FIRST USE

Wash the Rice Bowl, the Lid, the Measuring Cup and the Spatula in warm, soapy water. Rinse and dry thoroughly. Wipe the Base with a clean, damp cloth. Dry thoroughly. Do not use harsh detergents or abrasive cleansers on any parts of the appliance. Never immerse the Base in water or any other liquid.

HOW TO COOK RICE

IMPORTANT : Before each use, make sure that the outside of the Rice Bowl is clean, dry and free of any grains of rice so that the underside of the Rice Bowl makes good contact with the Heating Plate inside the Rice Cooker. Also ensure that the Heating Sensor in the center of the Heating Plate is clean, dry and cool.

Handle the Rice Bowl carefully. Scratching, denting or bending the Rice Bowl out of shape may result in unsatisfactory performance.

NOTE: There are differing opinions about whether rice should be washed before cooking. Those in favour argue that this washes away the starch content and ensures non-sticky grains. Those against feel valuable soluble vitamins and minerals are lost. Drier, fluffier rice is obtained by pre-washing rice. To pre-wash rice, rinse uncooked rice in Rice Bowl with cold water and drain thoroughly.

1. Measure rice and water and place evenly in Rice Bowl. **NEVER PUT ANY LIQUID INTO THE BASE.**
2. Place Rice Bowl in Base, and Lid on Rice Bowl.
3. Plug cord into a 120 Volt AC outlet.
4. Depress the Switch to start cooking and the red Cooking Indicator Light will glow. When cooking is complete, the Switch will move to the 'Warm' position and the amber Indicator Light will glow. Fluff rice with the spatula as soon as the red light goes out. The rice can be served immediately or close the Lid and leave the rice in the Rice Cooker.

It is not recommended to use the 'WARM' cycle for longer than 2 hours.

IMPORTANT:

YOUR RICE COOKER WILL REMAIN IN THE 'WARM' CYCLE UNTIL IT IS MANUALLY TURNED OFF.

ALWAYS REMEMBER TO UNPLUG FROM THE WALL OUTLET WHEN YOU ARE DONE USING YOUR RICE COOKER.

NOTE: Before removing the Rice/Cooking Bowl from the Rice Cooker, always unplug the power cord from the wall outlet.

RICE COOKING CHART

The following chart should be used only as a guide. The ratio of rice to water may need to be adjusted according to the kind of rice you are using. Please check the package directions.

	Salton Measuring Cup		Standard (8oz/250ml) Measuring Cup	
	UNCOOKED RICE	WATER	UNCOOKED RICE	WATER
For 2 cups cooked rice	1	1-1/2	2/3	1
For 4 cups cooked rice	2	2	1-1/3	1-1/3
For 8 cups cooked rice	4	4	2-2/3	2-2/3

NOTE:

1. The volume of cooked rice will vary depending on the type of rice used. You may wish to experiment until you find the proper proportions to suit your taste and needs.
2. For fluffier rice add slightly less water.
3. The one cup level in the Salton measuring cup is at the top rim. Do not overfill.

Flavoured Rice

- Prepare rice in Rice Cooker to obtain about 4 cups of cooked rice, except substitute chicken or beef broth for all of the water. Apple juice, orange juice, pineapple juice or tomato juice may also be substituted for half of the water.

Other Variations

To make plain rice more exciting, prepare rice in Rice Cooker, as directed, to obtain about 4 cups of cooked rice. Then use one of the following variations:

- Stir in 1/2 cup (125 ml) shredded carrot and 2 tablespoons (30 ml) margarine or butter, melted.
- Stir in 1/2 cup (125 ml) chopped or sliced ripe or pimento-stuffed olives.
- Cook 2 tablespoons (30 ml) finely chopped onion in 1 tablespoon (15 ml) margarine or butter, stirring occasionally, until tender; stir into rice.
- Stir in 2 teaspoons (10 ml) lemon juice and 2 tablespoons (30 ml) margarine or butter, melted.
- Cook 1/2 cup (125 ml) slivered almonds in 2 tablespoons (30 ml) margarine or butter, stirring occasionally, until light brown; stir into rice.
- Stir in 1/2 cup (125 ml) canned sliced mushrooms or mushroom stems and pieces, drained.
- Stir in 2 tablespoons (30 ml) chopped, fresh parsley.

CARE AND CLEANING

After each use, wash the Rice Bowl, the Lid, the Measuring Cup and the Spatula in warm, soapy water. Do not use harsh detergents, abrasive cleansers or metal scouring pads. Rinse and dry thoroughly. Wipe the base with a clean, damp cloth and dry. NOTE: If rice has cooked onto the bottom of the Rice Bowl, fill the bowl with hot, soapy water. Let stand about 10 minutes.

CAUTION:

1. To reduce the risk of electric shock, cook only in removable container. Do not immerse the Base, Cord or Plug in water or other liquid.
2. If water should accidentally enter the switch mechanism or spill onto the heating plate, carefully unplug the power cord from the wall outlet. Allow to dry thoroughly before using the appliance again.

A short supply cord is provided to reduce the hazards of becoming entangled in or tripping over a long cord. Extension cords may be used if care is exercised in their use. If an extension cord is used, the marked electrical rating of the detachable power-supply cord or extension cord should be at least as great as the electrical rating of the appliance. If the appliance is of the grounded type, the extension cord should be a grounded 3-wire cord. The extension cord should be arranged so that it will not drape over the counter top or table top, where it can be pulled on by children or tripped over.

LIMITED WARRANTY

Salton Canada warrants that this appliance shall be free from defects in material and workmanship for a period of one year from the date of purchase. During this 'in-warranty' period, defective products will be repaired or replaced at the discretion of the retailer and/or Salton Canada. This warranty covers normal domestic usage and does not cover damage which occurs in shipment or failure which results from alteration, accident, misuse, abuse, glass breakage, neglect, commercial use or improper maintenance.

A defective product should be returned to the original place of purchase within the retailer's stipulated return/exchange period*. If you are unable to have a defective product replaced under warranty by the retailer, please check our website at "www.salton.com" for the service centre nearest you. You may also contact us for assistance by mail, e-mail, fax or telephone as listed below.

To ensure prompt 'in-warranty' service securely package and return the product to us prepaid. Be sure to include the original proof of purchase and a description of the defect along with your address and postal code.

For repairs not covered by the warranty, please contact us for assistance.

SALTON CANADA

Customer Service Department

81A Brunswick,

Dollard-des-Ormeaux,

Quebec, Canada H9B 2J5

website: www.salton.com

E-mail: service@salton.com

Fax: 514-685-8300

Tel: 514-685-3660 Ext.226

* Return/exchange policies at each retailer vary and may differ from the SALTON Canada 1 year limited warranty period.